



TeleStepper CAT# 6907 Setup and Operators Guide
(Including Optional Auxilliary Kit Setup)

3/2/2022

Package Contents (shown below unless otherwise noted)

Quantity	Description
1	Remote Control
1	Stand 1
1	Stand 2
2	Wall Power Supplies
1	50 foot RJ45/Ethernet Cable (located in the case lid)
2	10 foot RJ45/Ethernet Cable
1	RJ45 Coupler
1	1/8" Hex Wrench
2	Mirror Clamps
2	Baseplates
2	PTZ Plate/Adapter Assemblies (optional accessory)
2	Mic Adapter Kits (optional accessory)
2	Extensions, Stand 18" (optional accessory)
2	Monitor Adapter Plates (not shown). Note: If Aux Kit ordered, monitor adapter plates will be installed on monitors.



Two Stand "Presidential System" Setup

- 1) Remove the two round baseplates, place them on the floor, side up as shown below:



- 2) Remove the two Stands and place them on the baseplates. Align the Stands with the 4 thumbscrews as shown below:

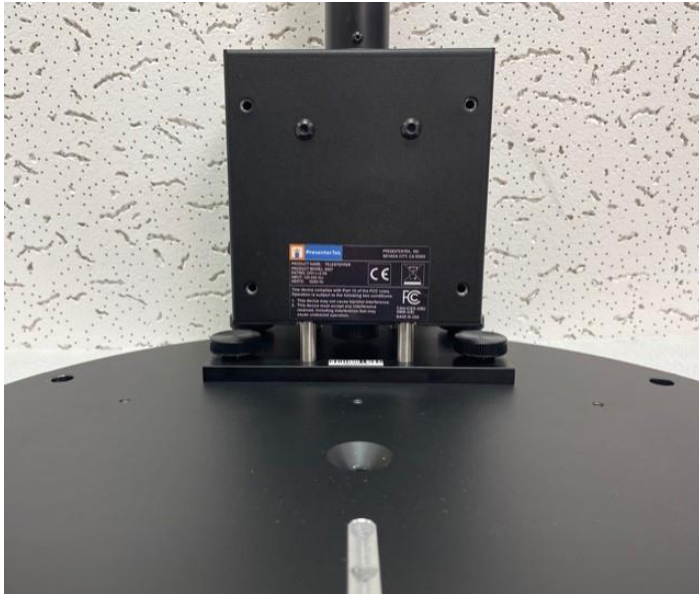

Note: The two stands are unique, Stand 1 (for Remote Control) and Stand 2. Place labels toward speakers and Stand connections facing each other.



- 3) Unpack the Mirror Clamps and attach to each of the Stand's upper rod. Secure with thumbscrew. Note that 2 extra thumbscrews are provided. If desired, 2 low profile hex screws are provided.



- 4) The angle of the mirror is 45 degrees to the stand and can be adjusted ± 4 degrees using the $1/8$ " hex wrench.



- 5) Place each Stand at the desired location. Typical orientation: Stand 1 is on left and Stand 2 is on right if connector ports are facing the presenter.

2-Stand System Cabling, Step by Step Instructions

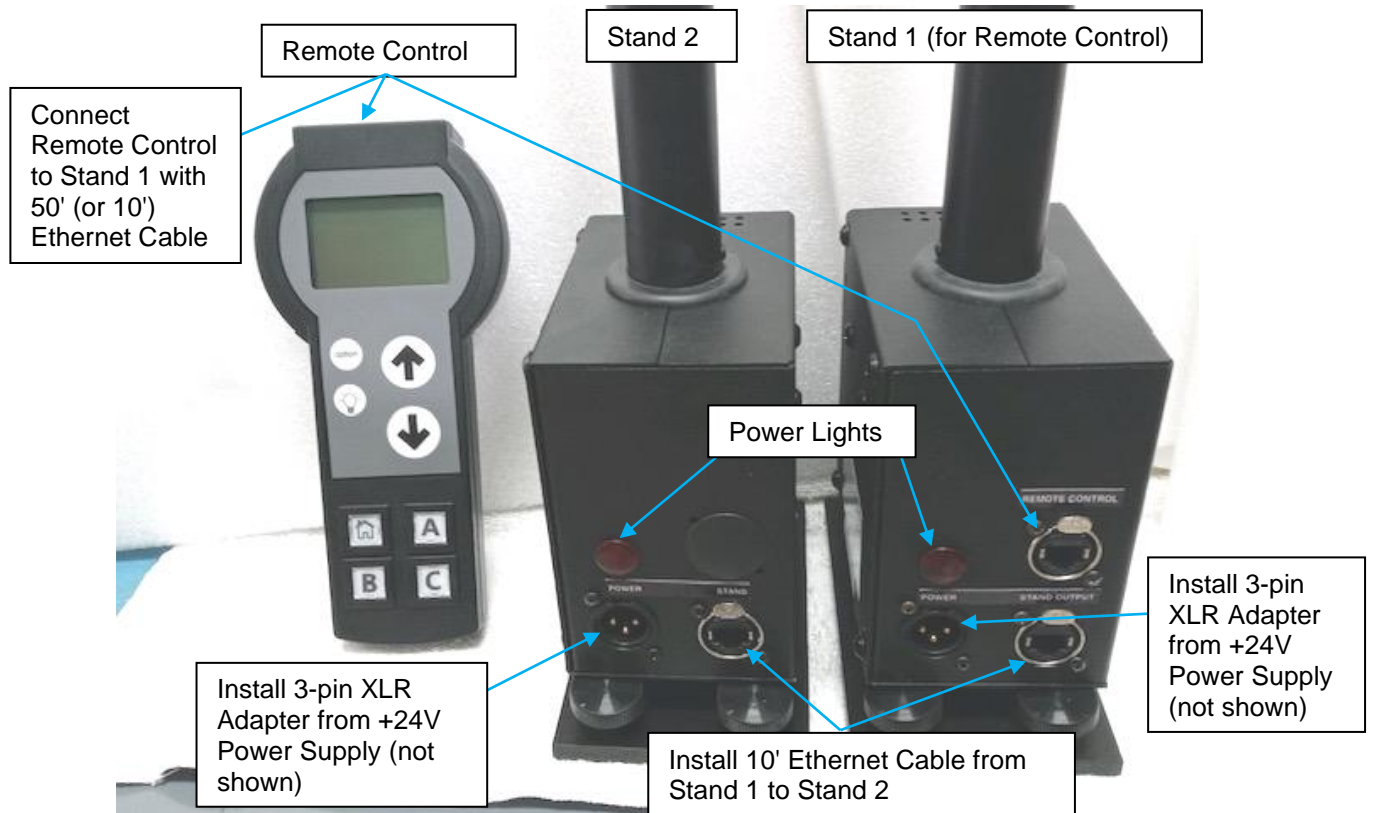

- 6) Connect the 10 foot RJ45/Ethernet Cable from Stand 1's "**Stand Output**" connector to Stand 2's "**Stand**" input.
- 7) Plug the 50 foot RJ45/Ethernet Cable into Stand 1's "**Remote Control**" input.
Note: To create a control cable longer than 50', use the RJ45 Coupler with the extra 10' cables. Longer Cat 5 or higher Ethernet cables can also be used, up to 1000 feet.
- 8) Plug the RJ45/Ethernet Cable into back of the Remote Control. The Remote Control must be plugged into Stand 1's "Remote Control" RJ45 connector.



Warning!

Do not plug this Ethernet cable from the Stand's Remote Port into any other Ethernet devices, Routers, PC ... The +24V power could damage these devices.

- 9) Connect the 3-pin XLR power connector to each stand's **"Power"** input. Plug the AC power cord into the IEC connector on the +24V supply and the remaining end into a wall outlet.

The Red power light should be illuminated.



- 10) When Stand 1's power is applied, the following will appear on the Remote Control's display. Note the firmware version and back-light will briefly illuminate.



- 11) The display will then show the following:

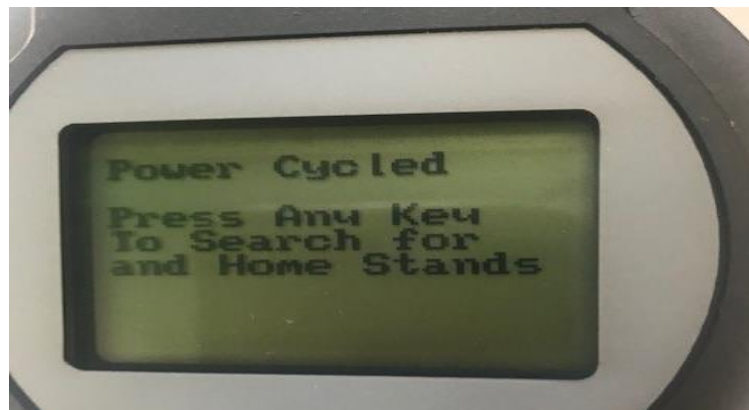

- 12) Make sure all Stands are powered up and cabled correctly. Press any key on the remote control to continue. When any key is pressed, the Remote-Control will search for Stands. After the search is completed, the following message will appear:



- 13) Verify the expected number of Stands are found.



- 14) After the search, each Stand is sent to Home or "0" position.



- 15) Once homing is complete, the display appears as follows:
Note: The control buttons on Remote-Control are now active.



2 Stand System -- Cabling Diagram

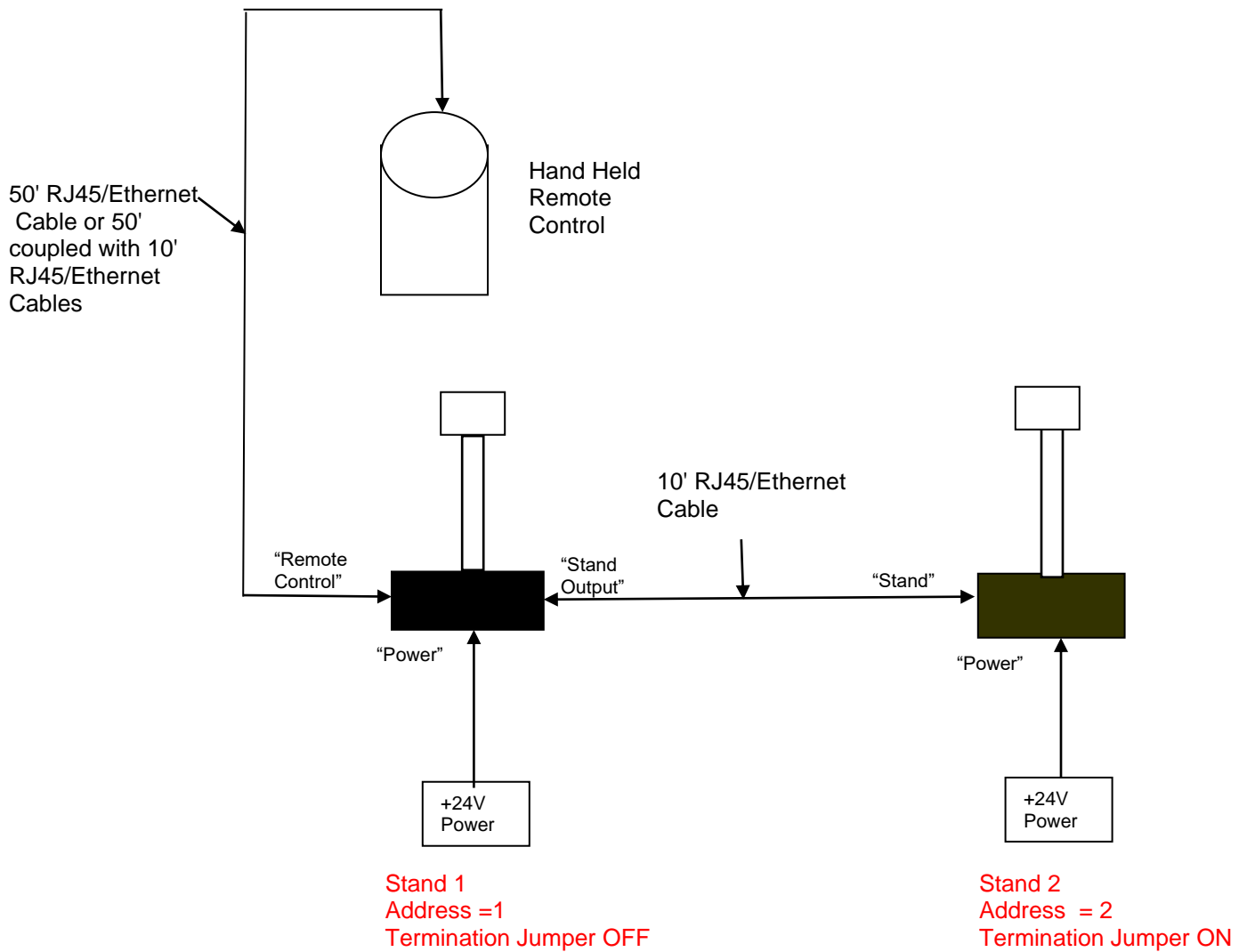

Operation:

Stand Operation is controlled by an 8-key remote control. Status is displayed on the LCD display.

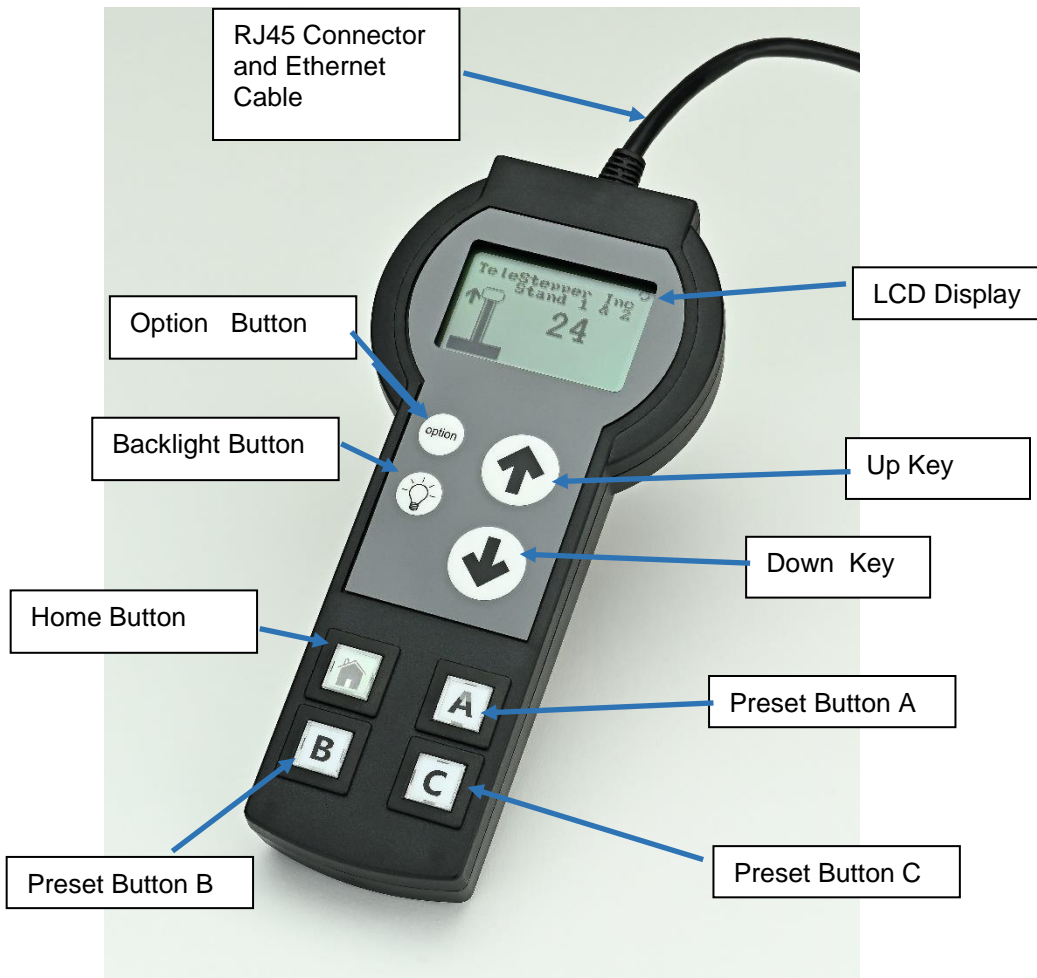

Key/ Buttons Description

Key/Button	Function
Up	Moves Stand Upwards in 0 –24 increments. Each increment is 1 inch from the bottom home or zero position.
Down	Moves Stand downwards
Backlight	Toggles Remote Control Backlight
Option	Allows for individual Stand control
Home	Moves Stand(s) to lowest 0 or home position
A	Preset position A, press to move Stand(s) 8 inches from Home*.
B	Preset position B, press to move Stand(s) 16 inches from Home*.
C	Preset position C, press to move Stand(s) 24 inches from Home*.

* 8,16 and 24 are the Factory Default Values for Preset Buttons - A, B and C can be customized as shown on next page.

Preset Buttons - Home, A, B and C

There are 3 Preset and 1 Home buttons.

The Home button moves the active Stand, or Stands, to the lowest or home position. The button will be illuminated when pressed. It will also illuminate whenever the stand(s) are moved to the lowest position, or 0, using the Down key.

Preset A, B or C buttons will move the active Stand, or Stands, to the preset positions. The respective button will be illuminated when pressed.

To set Presets, first, move the Stand or Stands to the desired location with Up (Or Down) buttons. Then, **ensure that the stand(s) are idle**, press and hold each button for approximately 3 seconds. The button will blink, and "Preset A Set", "Preset B Set" or "Preset C Set" respectively will indicate on the LCD at bottom of display. Once each button is released, it will stay illuminated.

Note that each preset is non-volatile, they will remain in memory after cycling the power. Also, each active Stand or Stands will have its own unique presets. That is, if Stand 1 and 2 are active, it will have a unique preset than if only Stand 1 is selected.

LCD Display

Section	Meaning
Stand Height	Stand height in 0 –24 increments. 0 = bottom position, 24 = top. Each increment is 1 inch from bottom or 0 position
Stand Height Graphic	Graphical representation of stand height
Stand Moving Circular Arrows	Indicates Stand(s) are moving
Stand Moving Up/Down Arrow	Indicates Stand(s) are moving Up or Down depending on arrow direction
Max/Min	Indicates system ignored Up or Down key press because it is at limit
Stand(s) Controlled	Indicates which Stands are currently being controlled by remote
Warning Indicator (Triangle Icon at top of display- not shown below)	System error has occurred
Error Message (not shown below)	Displays system error message at bottom of Display. Note: If error code displays, clear error code by plugging and unplugging remote. If error code persists, note error code and contact PresenterTek for assistance.

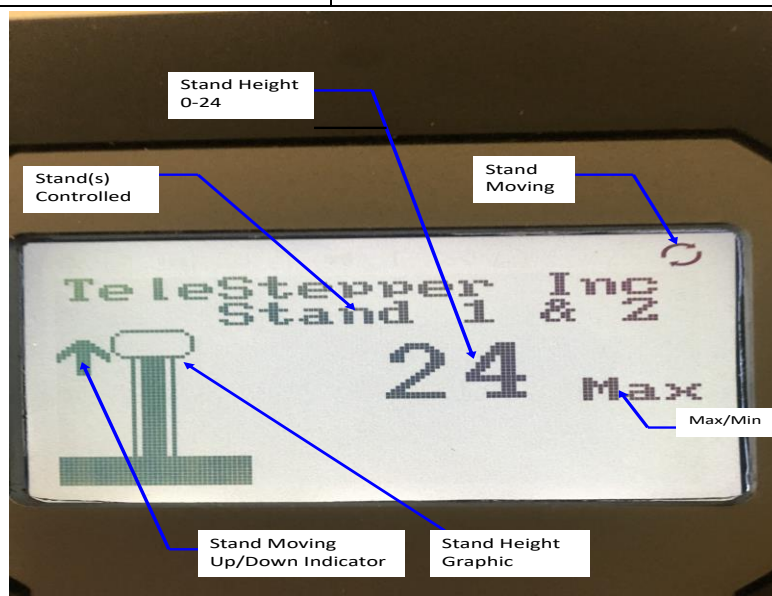

Controlling Individual Stands

Each Remote Control can control up to 4 Stands. Using the PresenterTek optional Stand Controller Software, up to 8 stands can be controlled. The description below is for a 2 stand system.

- 1) Press Option Key and the following menu will be displayed.
- 2) Use Up or Down arrow keys to highlight desired option.
- 3) Press Option key to select and exit.

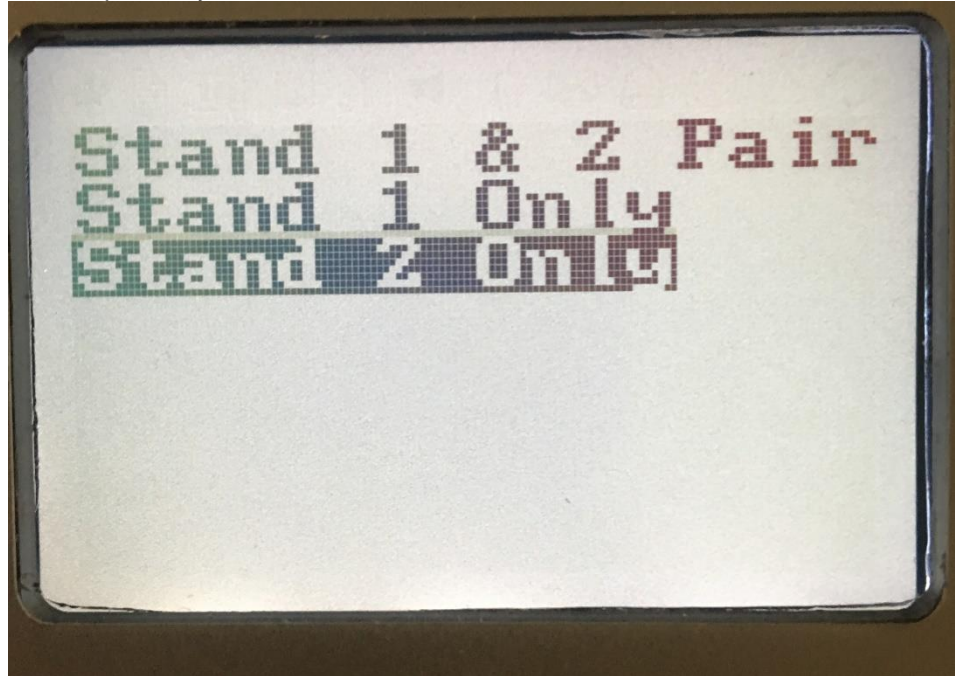

- 4) Stand's controlled section of the LCD display will be updated.



Note; When changing from individual to multiple Stands, the Stand height displayed will be of Stand 1; the second Stand may be at different height.
For example, Selecting Stand 2 and adjusting height, then going to Stand 1 and Stand 2 control, the current height of Stand 1 will be displayed. Stand 2 may be at a different height.

Cabling for more than 2 Stands

The Remote Control has the ability to control up to 4 Stands. Using the PresenterTek optional Stand Controller Software, up to 8 Stands can be controlled. Contact PresenterTek to obtain the Telestepper's software and an optional USB converter box.

Note: Each stand is unique, referred to as Stand 1 and Stand 2. Stand 1 has 2 RJ45/Ethernet connectors, a "Remote Control" connector in addition to the "Stand Output" connector. The "Remote Control" connector provides power to the Remote Control. Stand 2 has a "Stand" connector and does not provide power to the Remote Control.

- 1) Set each Stand's Address Switch and Termination Jumper as follows:
 - a. Remove plug on back of stand to expose the address switch and termination jumper.
Note: Plug can be carefully pried out of hole with a small flat head screw driver working around the circumference of plug.
 - b. First Stand in chain, set to address 1, remove termination jumper.
 - c. Second Stand, set to address 2, remove termination jumper.
 - d. Third stand, set to address 3 and so on. Use sequential addressing, address 1 for the first Stand, 2 for the second Stand, 3 for the next, etc.
 - e. Each address is set using the rotary switch on the back of the Stand. Turn the switch using a small flat head screw driver. In the figure below, Stand 3 is set to address 3.
 - f. Valid address switch settings are "1" through "8". Do not use any other address. One stand must always have address 1.
 - g. Install the termination jumper on last Stand in the chain (Stand furthest from the Remote-Control) in location shown below. Only the last Stand should have this jumper.
Note: Remove jumper(s) if installed on any other stands using a pair of tweezers. For convenience, the jumper can be placed on one post to keep it from getting lost.

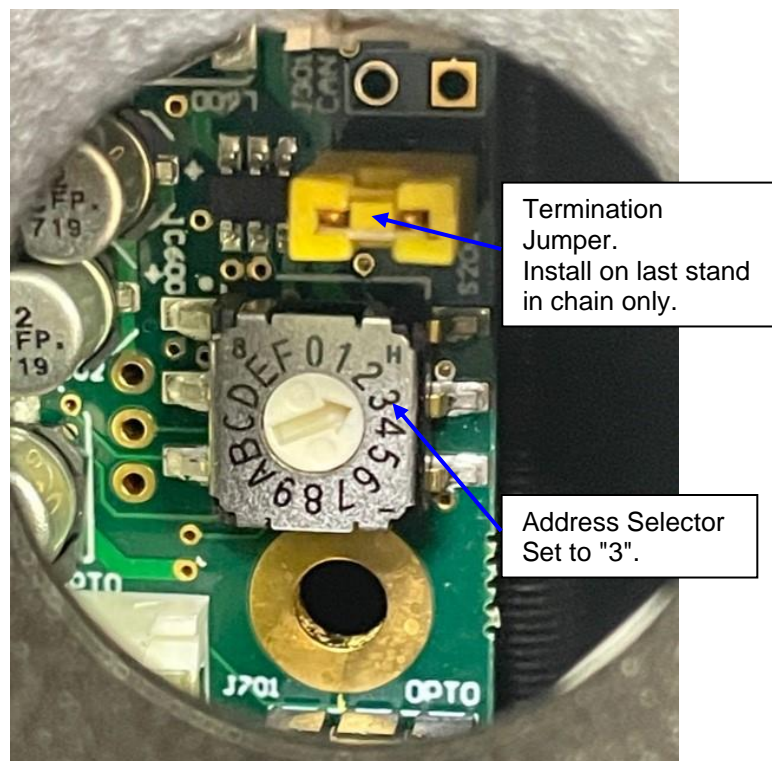

Stand Address set to 3, termination jumper installed

2) Using Ethernet Cables, wire system as shown in the diagram below.

Important: DO NOT connect two Stand 1's "Remote Control" RJ45 outputs together. It must be configured as shown in the diagram below:

- Hand-held Remote Control to Stand 1 "Remote Control"
- Stand 1 "Stand Output" to RJ45 Splitter
- RJ45 Splitter Output 1 to Stand 2 "Stand" input
- RJ45 Splitter Output 2 to Stand 3 "Remote Control" input
- Stand 3 "Stand" to Stand 4 "Stand", or RJ45 splitter if more than 4 Stands are daisy-chained

Daisy-Chaining more than 2 Stands -- Cabling Diagram

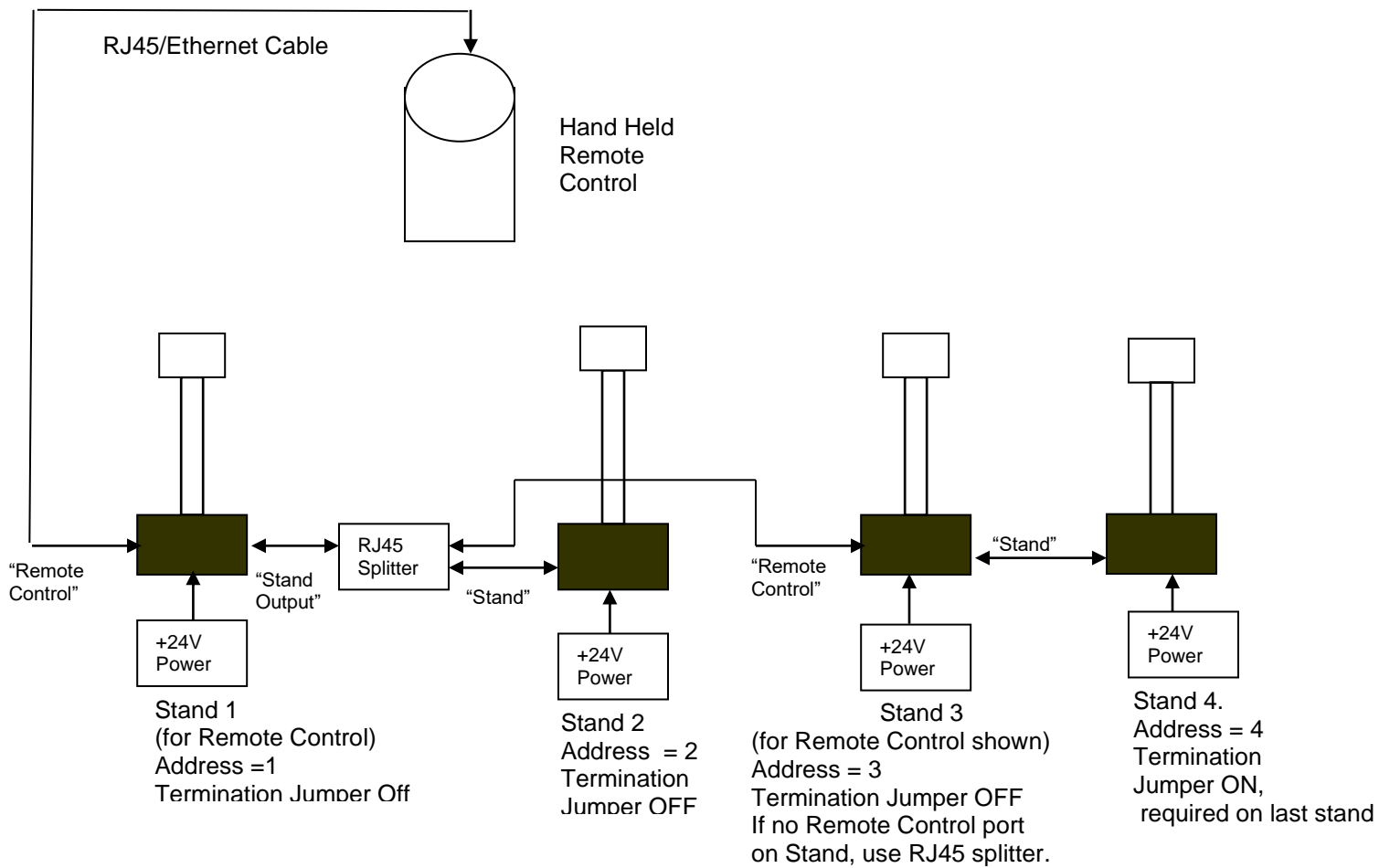

- Connect the 3-pin XLR to the "Power" input for each Stand and apply power. Ensure Red power light is illuminated for each stand.
- Ensure Stands are properly cabled and power is applied. If all cables are configured correctly, the following should appear, for a 4-Stand daisy chain on the LCD display. The correct number of stands found will appear on the LCD display.

"X Stand(s) Found"
Where X = 1 through 4, the number of stands connected

Demo Mode

To access a special demonstration mode, where all stands automatically move up and down, stopping at each of the 24 positions, perform the following:

1. Cycle power on Stand 1.
Note: This can be done by removing the RJ45 connector at the Remote Control, waiting 10 seconds and re-plugging connector.
2. The LCD will display a normal boot-up sequence.
3. Once " X Stands Found " (where X = number of stands connected) appears on the display, press and hold the ""OPTION" key.
4. After all Stands have homed, A special Sub Menu will be displayed.
5. Use "UP" or "DOWN" keys to select "On".
6. Press "OPTION" key to select.
7. To exit "Demo" mode, cycle power on Stand 1.

Auxiliary Kit- Optional, Separate Purchase

Aux Kit Package Contents

Quantity	Description
2	Teleprompting Glass, 11" x 14"
2	Teleprompting Monitors, 17", 1000 NTS with Power Cords
2	Monitor Adapter Plates (installed on monitors to interface with PresenterTek's Baseplates).
1	10' SDI Cable
1	HDMI to SDI Converter w/ USB Power Cable
1	75' SDI Cable
1	Scroll wheel

Note Customer-supplied Items: Laptop/PC with Teleprompting Software. PresenterTek recommends Presentationprompter.com (for MAC) and Magicscrollforwindows.com (for PC). HDMI cable from Laptop/PC length to be customer-defined. If using a MAC, a mini display port to HDMI converter is necessary.



Stands with Aux Kit

Aux Kit Layer 1 (Monitors with Monitor Adapter Plates)



Aux Kit Layer 2 (Glass, Cables, Scroll Wheel, Converter)

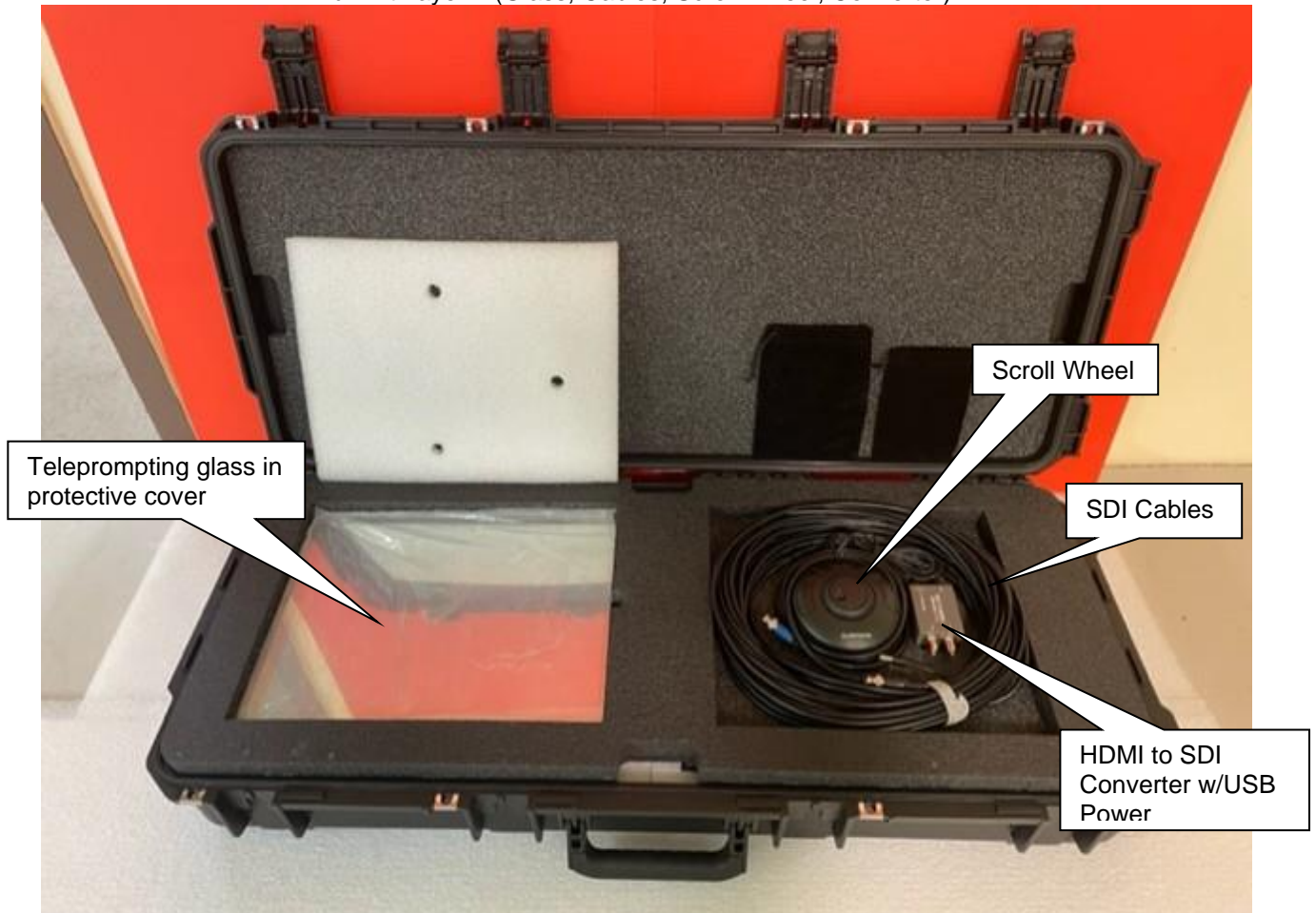

Aux Kit Final (before closing lid)



Aux Kit Cabling Configuration

